



STACK-O!

USER'S MANUAL

5/15/2023

CEP STACK-O! Manual Revision 2.1



		<p style="text-align: center;"><i>STACK-O! Testing System</i></p>
<p>TAG STACK-O! Manual Rev. 3.2</p>	<p style="text-align: center;">User's Manual</p>	<p style="text-align: center;">May 16, 2023</p>

Table of Contents

1.0	Introduction.....	2
2.0	System Overview	2
3.0	General Operation.....	3
4.0	Maintenance.....	7
5.0	System Specifications	10
6.0	System Warnings	10
7.0	Contact Details	11

		<p style="text-align: center;"><i>STACK-O! Testing System</i></p>
<p>TAG STACK-O! Manual Rev. 3.2</p>	<p style="text-align: center;">User's Manual</p>	<p style="text-align: center;">May 16, 2023</p>

1.0 Introduction

This manual is intended as a guide to the operation of the STACK-O! Testing System. The STACK-O! is used to periodically test the thickness of a product, such as a stack of cookies or crackers, for the purpose of quality control and to transmit the measurement data to an external database. This document should be used by technicians and operators involved in the operation and maintenance of the system.

2.0 System Overview

Each STACK-O! Testing System consists of a programmable logic controller with a built-in operator interface panel and two short range distance sensors. This system measures the height of a predetermined number of cookies or crackers that is arranged in a stack and displays the results in either inches or millimeters. Once the measurement is complete, the operator can transmit the data in ASCII format via a serial link to an external database. The data is transmitted in the same units as the displayed data.

Figure 1 – STACK-O! Features (front view)

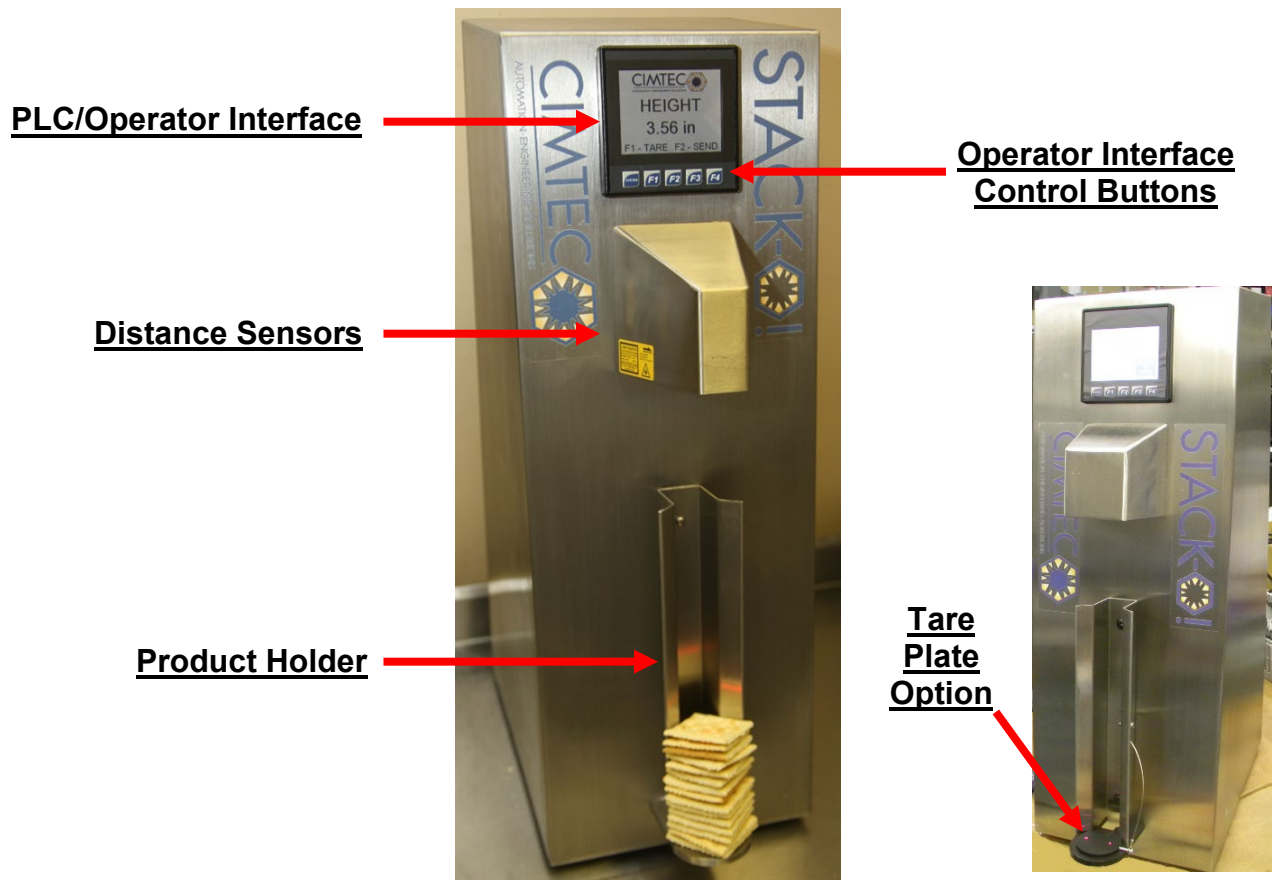

		<p><i>STACK-O! Testing System</i></p>
<p>TAG STACK-O! Manual Rev. 3.2</p>	<p>User's Manual</p>	<p>May 16, 2023</p>

Figure 2 – STACK-O! Features (rear view)



3.0 General Operation

3.1 Power-up

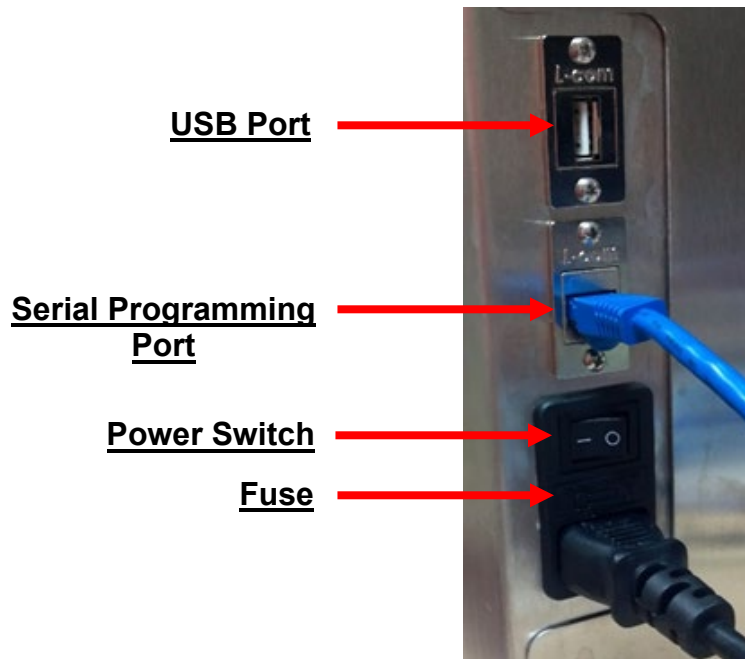
Remove all product material from the Product Holder. If it is required to collect the measurement data at your facility, connect the USB port to the data collection system designated for use with the STACK-O!. Power up the STACK-O!. Wait at least 15 minutes before measuring any product. This will allow the sensors' lasers to warm up and stabilize. Measuring product before the warm-up period is complete could result in inaccurate measurements.

		<p>STACK-O! Testing System</p>
<p>TAG STACK-O! Manual Rev. 3.2</p>	<p>User's Manual</p>	<p>May 16, 2023</p>

3.2 Setup and Calibration

After the warm-up period is complete, the following screen is displayed:

Figure 3 – STACK-O! Initial Screen



Press "TOUCH FOR SENSOR SETUP AND CALIBRATION". The following screen will be displayed:

Figure 4 – STACK-O! SENSOR SETUP Screen

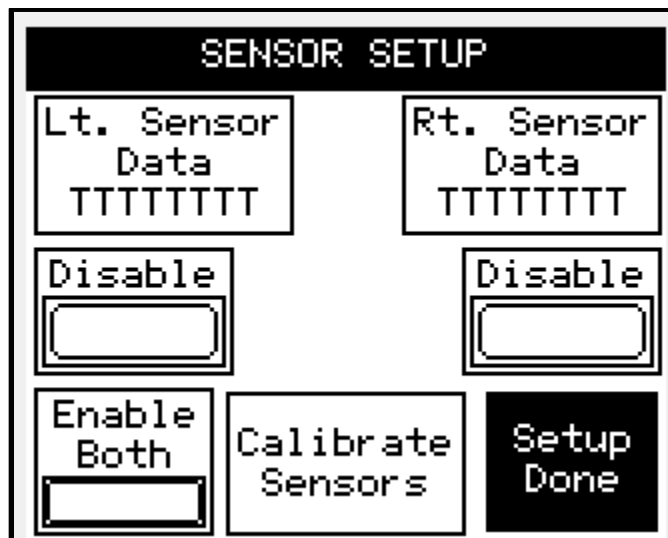

		<p style="text-align: center;"><i>STACK-O! Testing System</i></p>
<p>TAG STACK-O! Manual Rev. 3.2</p>	<p style="text-align: center;">User's Manual</p>	<p style="text-align: center;">May 16, 2023</p>

The SENSOR SETUP screen allows the user to calibrate the STACK-O!, and enable and disable the sensors. (By default, both sensors are enabled. A sensor should only be disabled when the sensor has failed. If the user disables one of the sensors, the user should recalibrate the STACK-O!.) Press “Calibrate Sensors” The following screen will be displayed:

Figure 5 – STACK-O! SENSOR CALIBRATION Screen

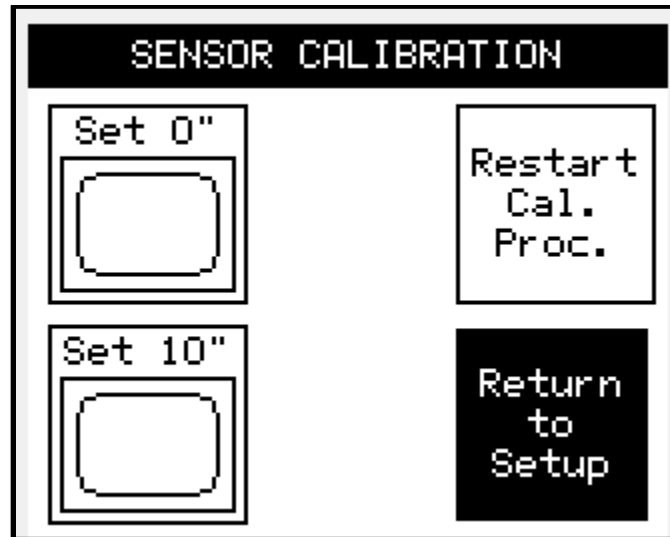

The SENSOR CALIBRATION screen, when used in conjunction with the STACK-O! 10-inch calibration rod supplied with the STACK-O!, allows the user to calibrate the STACK-O!. The calibration procedure is as follows:

1. Remove all product from the STACK-O! Product Holder and make sure that the Product Holder is clear of all debris. If the STACK-O! is equipped with the Tare Plate Option, place the Tare Plate on the Product Holder.
2. Press the “Set 0”” button on the screen. This sets the 0” point in the STACK-O!’s controller.
3. Place the 10” calibration rod on the Product Holder. If the STACK-O! is equipped with the Tare Plate Option, place the Tare Plate on top of the 10” calibration rod.
4. Press the “Set 10”” button on the screen. This sets the 10” point in the STACK-O!’s controller.
5. The STACK-O! is now calibrated. Press the “Return to Setup” button to return to the SENSOR SETUP screen and then press the “Setup Done” button to exit the SENSOR SETUP screen and to display OPERATOR measurement screen. Remove the 10” calibration rod from the Product Holder. If the STACK-O! is equipped with the Tare Plate Option, allow the Tare Plate to hang by its tether outside the Product Holder.

You can restart the calibration procedure at any time by pressing the “Restart Cal. Proc.” Button.

NOTE

Use of the Tare Plate is optional. The Tare Plate is meant to be used with product material that has an uneven surface. If the user decides to start or stop using the Tare Plate after initial calibration, the STACK-O! should be recalibrated accordingly.

		<p style="text-align: center;"><i>STACK-O! Testing System</i></p>
<p>TAG STACK-O! Manual Rev. 3.2</p>	<p style="text-align: center;">User's Manual</p>	<p style="text-align: center;">May 16, 2023</p>

3.3 Measurement

Figure 6 – STACK-O! OPERATOR Screen and Control Buttons

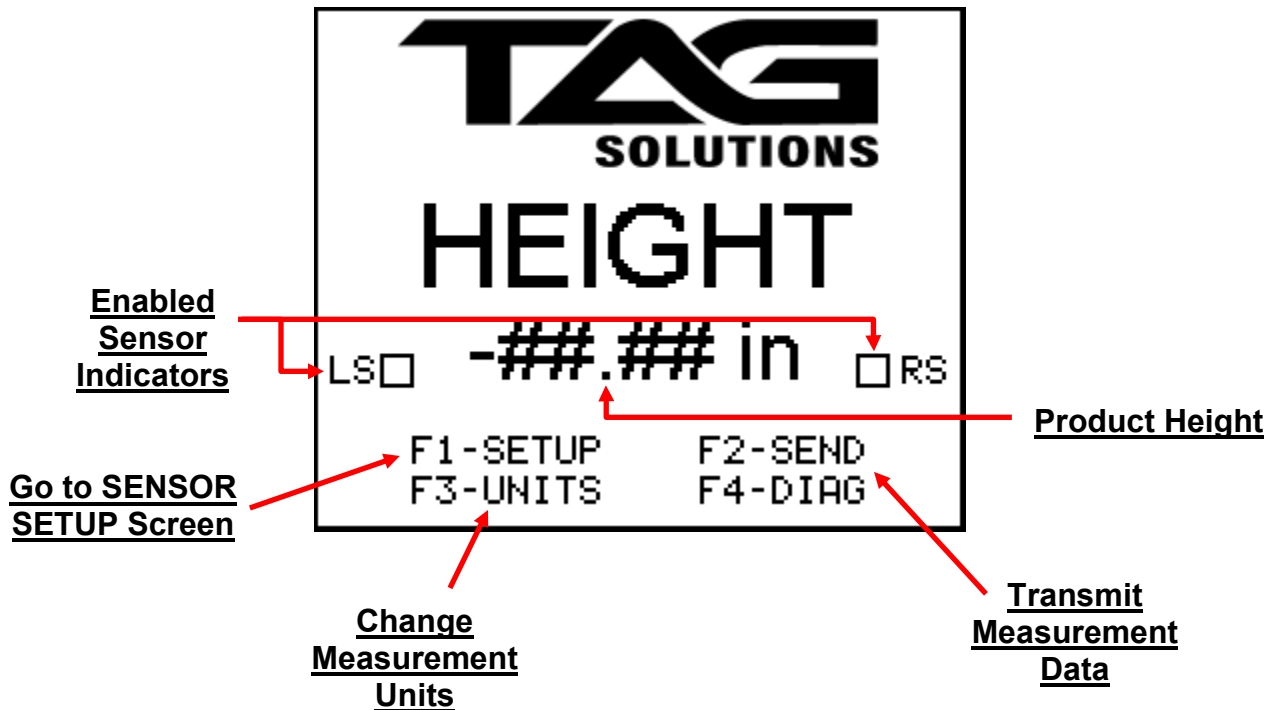

After the calibration procedure is completed and the user exits the SENSOR SETUP screen, the OPERATOR screen is displayed (Figure 6). The OPERATOR screen displays the height of the product being measured and which sensors are enabled. There are also additional features of this screen that are associated with the F Keys below the screen.

1. F1 – Press and hold this button to go to the SENSOR SETUP screen.
2. F2 – Press this button to transmit the measurement data out of the USB port.
3. F3/F4 – Press one of these buttons to select the units of measurement – F3 for millimeters and F4 for inches.

In order to measure a stack of product material, place the stack of product material in the Product Holder. (See Figure 7.) If the STACK-O! is equipped with the Tare Plate Option and the Tare Plate was used during the calibration procedure, place the Tare Plate on top of the product material. The STACK-O! will begin measuring the stack immediately. Once the stack has been measured, press F2 to transmit the measurement data via the USB port to your facility's data collection system (if required). Please note that the transmitted data will be in the same measurement units as is displayed on the OPERATOR screen.

Once the measurement is complete, remove the product material from the Product Holder. After the reading returns to zero, STACK-O! is ready for the next measurement.

		<i>STACK-O! Testing System</i>
TAG STACK-O! Manual Rev. 3.2	User's Manual	May 16, 2023

Figure 7 – Product Stack Placement



4.0 Maintenance and Program Updating

4.1 Cleaning

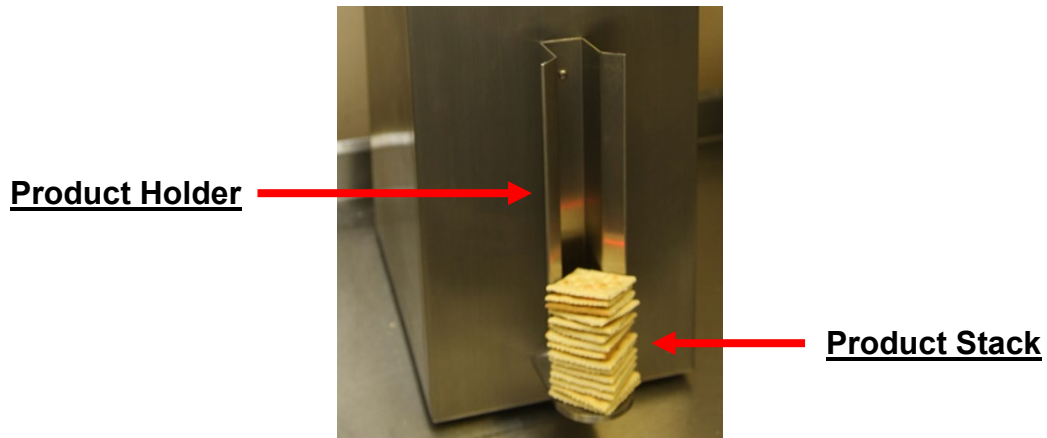
To clean the STACK-O! case use a dry cloth to wipe it down. In those cases where stains need to be removed, spray window cleaner onto the cloth and then wipe down the STACK-O!. **DO NOT WASH DOWN THE STACK-O!. THE STACK-O! IS NOT RATED FOR THIS TYPE OF CLEANING.**

It is recommended to regularly clean the external lens surfaces of the short range distance sensors with a dry cloth. (See Figure 8 for lens location.) **Only clean the lenses when the STACK-O! is powered down.**

		<p style="text-align: center;"><i>STACK-O! Testing System</i></p>
<p>TAG STACK-O! Manual Rev. 3.2</p>	<p style="text-align: center;">User's Manual</p>	<p style="text-align: center;">May 16, 2023</p>

Figure 8



4.2 Calibration

The short range distance sensors used in the STACK-O! are calibrated at the factory. Overall system calibration is done by following the calibration procedure in section 3.2 – Setup and Calibration. Access to the SENSOR SETUP screen can be attained by powering the STACK-O! down, powering it up and waiting for the warm-up period to expire or by pressing and holding F1 for at least 5 seconds while displaying the OPERATOR screen.

4.3 Program Updates

Program updates to the STACK-O! may be performed periodically to address operational issues or to add enhancements and features. Prior to updating the program in the STACK-O!, the latest version of **Cscape**, the programming software used to program and configure the PLC used in the STACK-O!, must be downloaded from <http://www.heapg.com/> and installed on the PC that will be used to update the program in the STACK-O!. Instructions for using Cscape to update the STACK-O! will be provided with the update files by Cimtec Automation LLC when program updates become necessary.

		<p style="text-align: center;"><i>STACK-O! Testing System</i></p>
<p>TAG STACK-O! Manual Rev. 3.2</p>	<p style="text-align: center;">User's Manual</p>	<p style="text-align: center;">May 16, 2023</p>

4.4 Troubleshooting

<u>PROBLEM</u>	<u>POSSIBLE CORRECTIVE ACTION</u>
<p>STACK-O! does not power up.</p>	<ul style="list-style-type: none"> • Confirm that the STACK-O! power source is present and within specification. • Check the fuse and replace if necessary.
<p>STACK-O! powers up but main screen with CIMTEC logo and height data does not appear on screen after the power-up screen disappears.</p>	<ul style="list-style-type: none"> • Go to System Setup Screen by pressing the System button and confirm that the PLC Status is “Run”. If not, maneuver to the Status line, press the Enter ↵ button and use the arrow keys to change the Status to “Run” and press the Enter ↵ button. Confirm that the Status is “Run” and press the “Esc” button twice. The main screen should appear. • If the PLC Status is “Run” and the main screen does not appear, please contact CIMTEC for further assistance.
<p>STACK-O! powers up but one or both of the short range distance sensors’ lasers do not appear to be on.</p>	<ul style="list-style-type: none"> • Power down the STACK-O! and confirm that the sensor’s lens is clean and unobstructed.
<p>Incorrect measurements.</p>	<ul style="list-style-type: none"> • Remove all product from the STACK-O! and recalibrate the STACK-O! (section 3.2), then re-check the measurements.

4.5 Maintenance

There is no scheduled maintenance for the Stack-O! or any of its electrical components.

		<i>STACK-O! Testing System</i>
TAG STACK-O! Manual Rev. 3.2	User's Manual	May 16, 2023

5.0 System Specifications

GENERAL SPECIFICATIONS	
Input Voltage	100 - 240VAC
Input Current	1.2 - .66 Amps
Frequency Rating	50/60 HZ
Ambient Temperature	0°C to 40°C
Relative Humidity	5 to 95% Non-condensing
Altitude	< 2000 m
Accuracy	± 0.01 in. after 10 minute warm-up and calibration operation
Tolerance	± 0.005 in. after 10 minute warm-up and calibration operation
Repeatability	0.01 in.
USB Port	Powered externally from user's USB device (ex. PC or USB hub) Serial communication parameters are 9600 bps, 8 Data Bits, No Parity 1 Stop Bit

6.0 System Warnings

6.1 Warning Symbols



Figure 9

This indicates a Class 2 Laser Product. Laser Radiation is emitted from the laser aperture. Avoid exposure with laser aperture. Do not stare into beam.

6.2 Statement of Warning

The Stack-O! should not be used outside of the intended function as specified in the preceding sections of this user manual.

		<i>STACK-O! Testing System</i>
TAG STACK-O! Manual Rev. 3.2	User's Manual	May 16, 2023

7.0 Contact Details

Corporate Headquarters:

CIMTEC Automation, LLC
3030 Whitehall Park Drive
Charlotte, NC 28273

Phone: (877) 524-6832

Phone: (704) 227-4600

FAX: (704) 583-9671